

DALI & Push Dimmable driver - constant voltage 150W

Whole Family
KV-XXXX-DP 12V 24V DC
25W 50W 75W 80W 100W 120W
150W 200W 300W 320W 360W



IP66 SELV

■ Features:

- Output constant Voltage
- Range: 100-265VAC
- Built-in active PFC function
- Efficiency up to 88%
- Protections: short circuit/over load/ over temperature
- Cooling by free air convection
- IP66 design for indoor and outdoor installation.
- Dimming function: Built in DALI interface dimming function conform to DALI Protocol IEC62386
- Push dimming function
- Dimming range: 0-100%, LED start at 0.1% possible
- Suitable for intelligent LED lighting

■ Specification

Model		KV-12150-DP	KV-24150-DP
Output	DC Voltage	12V	24V
	Voltage Tolerance	±0.5V	
	Voltage Regulation	±0.5%	
	Rated current	12.5A	6.25A
	Rated power	150W	
	Load Regulation	±2%	
Input	Voltage Range	100-265VAC	
	Frequency Range	47 - 63Hz	
	Power Factor (Typ.) @ full load	PF≥0.99/120VAC PF≥0.96/230VAC (Full loading)	
	THD (Typ.) @ full load	<20%	
	Efficiency (Typ.) @ full load	88%	88%
	AC Current (Max.)	1.72A	1.72A
	Inrush Current (Typ.)	16A/120VAC 56A/230VAC	
	Leakage current	<0.5mA	
Protection	Short Circuit	constant current mode, recover automatically after fault condition is removed	
	Over Load	≤120% constant current limiting, recover automatically after fault condition is removed	
	Over temperature	100°C±10°C Shut down o/p voltage, recovers automatically after temperature goes down	
	Protection Class	I	
Environment	Working TEMP.	-40~+60°C (see below derating curve)	
	Working Humidity	20 - 95%RH, non-condensing	
	Storage TEM., Humidity	-40 - +80°C, 10 - 95%RH	
	TEMP. coefficient	±0.03%/°C (0 - 50°C)	
	Vibration	10~500Hz, 5G 10min./1 cycle, period for 60min. each along X,Y,Z axes	
Safety & EMC	Safety standards	EN61347-1 EN61347-2-13 IP66	
	Withstand voltage	I/P-O/P:3.75KVAC I/P-FG:1.88KVAC O/P-FG:0.5KVAC	
	Isolation resistance	I/P-O/P I/P-FG O/P-FG: 100MΩ/500VDC/25°C/70%RH	
	EMC Emission	EN55015 EN61000-3-2 EN61000-3-3	

DALI & Push Dimmable driver - constant voltage 150W

	EMC Immunity	EN61000-4-2,3,4,5,6 ,11, EN61547
Others	Weight	1.2Kg
	Dimension	245*70*43mm (L*W*H)
	packing	320*270*170mm/10pcs /CTN
Notes	<p>1. All parameters NOT specially mentioned are measured at 230VAC input , rated load and 25°C of ambient temperature.</p> <p>2. Tolerance: includes set up tolerance, line regulation and load regulation .</p> <p>3. The power supply is considered as a component that will be operated in combination with final Equipment. Since EMC performance will be affected by the complete installation, the final equipment manufactures must be-qualify EMC Directive on the complete installation again.</p>	

■ Mechanical Specification

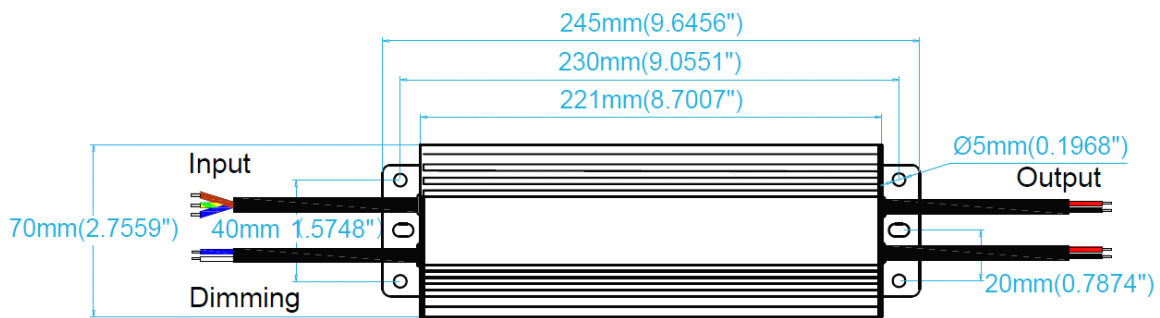

KV-12150-DP

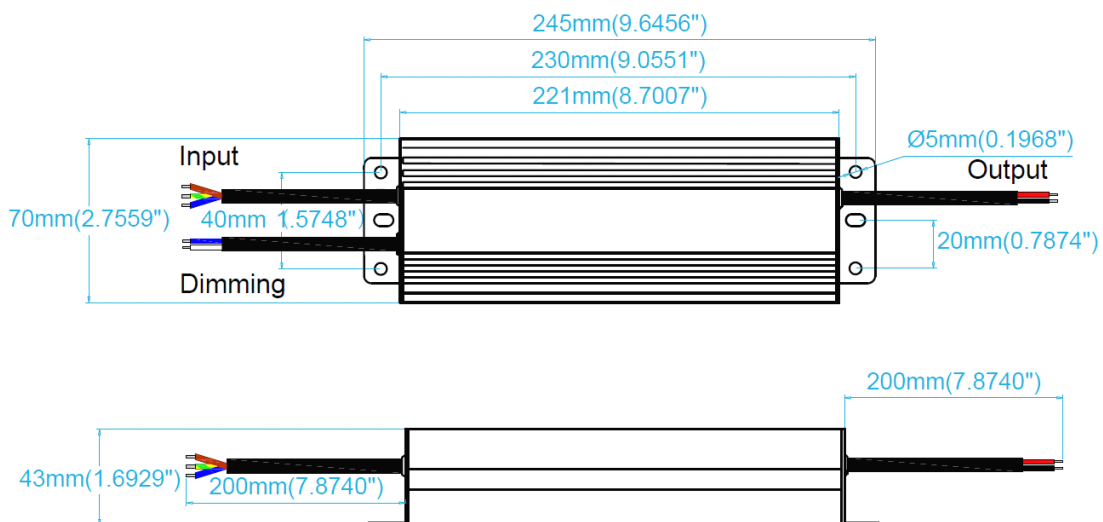

KV-24150-DP

DALI & Push Dimmable driver - constant voltage 150W

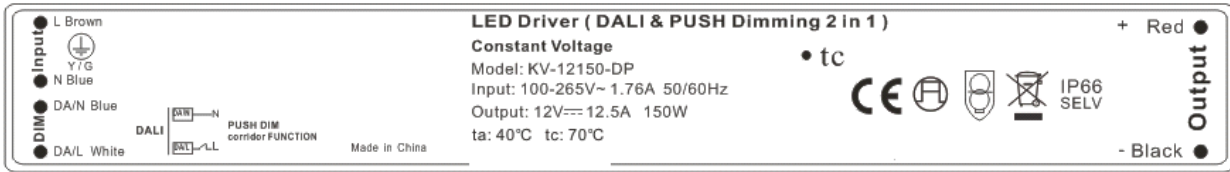

Input & Output wiring

- ※Input Rubber cable 3*1.0mm², the green/yellow cable connect with (FG), Brown with AC (L), Blue with AC(N)
- ※Output rubber cable 2*1.5mm², Red is output (V+) Positive, Black is output (V-) negative. Connected to LED Lamps.

Dimming wiring

- ※Dimming Rubber cable 2*0.75mm², Blue DA/N and White DA/L (No polar) connected to the DALI BUS when use DALI function.
- Blue (N) and Brown (L) connect to AC (N) and Push dim switch dimmer (L) when use Push function.
- ※Please make sure you connect these correctly otherwise your product will not function correctly and could be damaged.
- ※Note: Any other requests we can customized.

■ Dimming Operation

DALI Dimming Wiring Diagram1

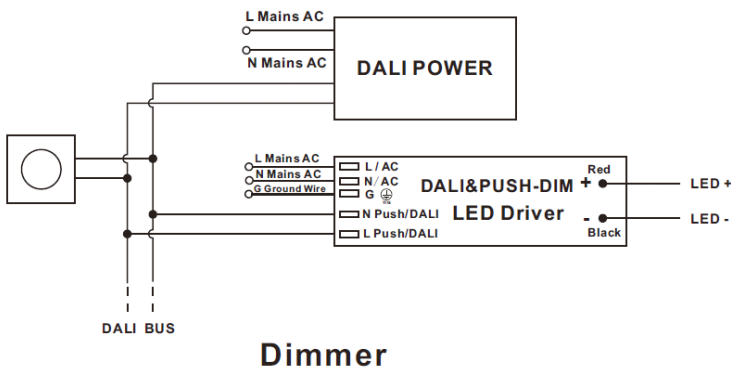

DALI Dimming Wiring Diagram2

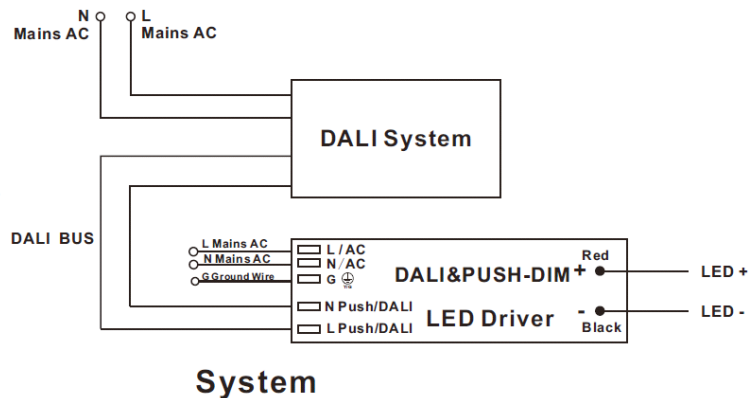

DALI Dimming Wiring Diagram3

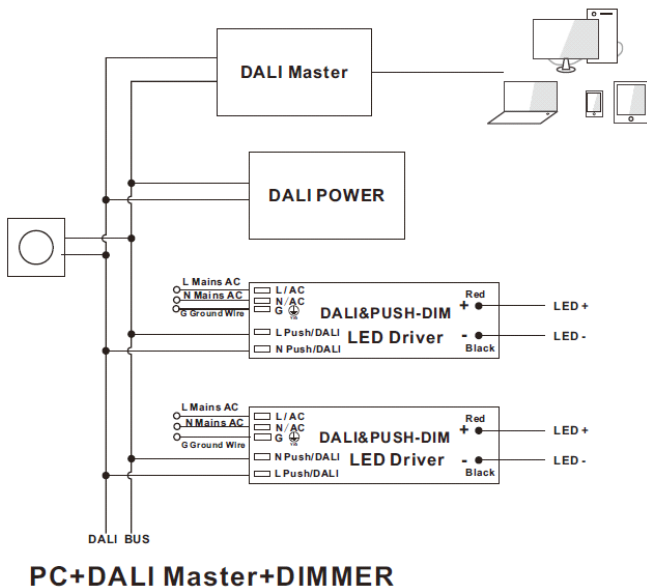

Push-Dimming Wiring Diagram1

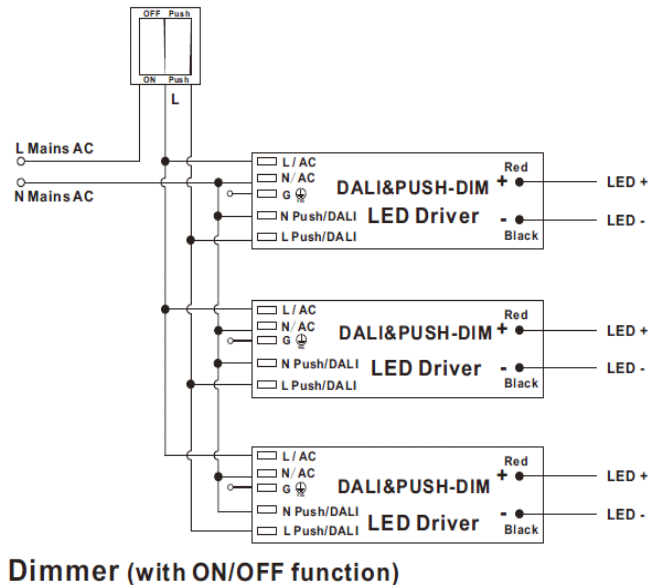

DALI & Push Dimmable driver - constant voltage 150W

Push-Dimming Wiring Diagram2

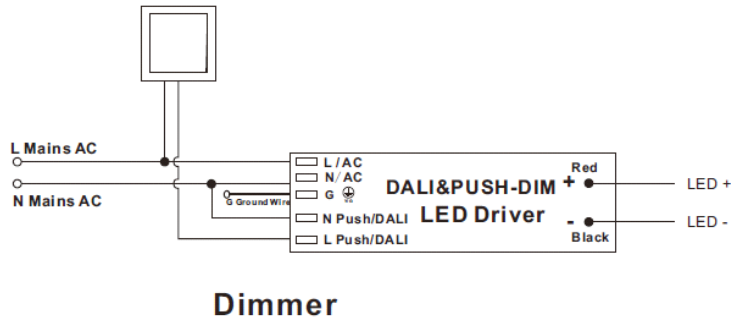

※Note: For DALI Dimming Wiring Diagram 3, please noted that only one DALI power is need in the DALI bus, so no extra DALI power is needed if the Master or Dimmer already includes the DALI Power.

■ Derating Curve

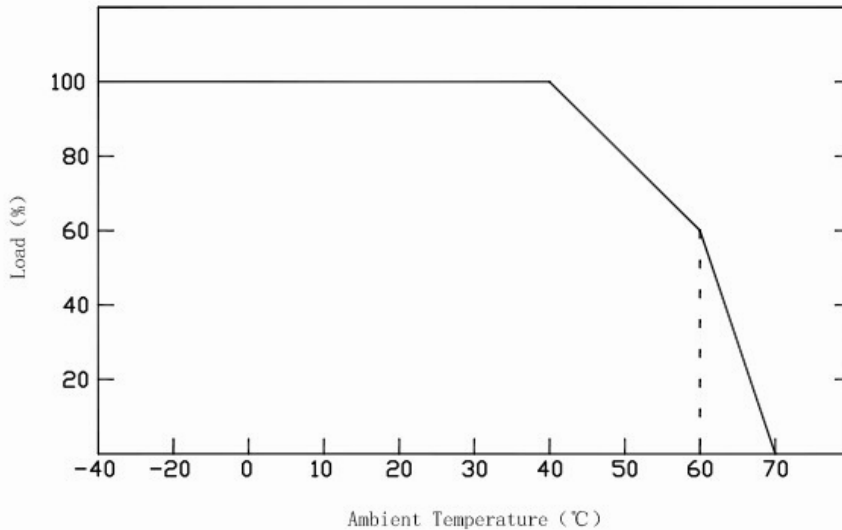

※To extend their life, please refer to the Derating Curve and derate according to the temperature.

■ Instruction:

- 1)This driver should be installed by qualified and professional person;
- 2)Please make sure the driver is installed with adequate ventilation around it to allow for heat dissipation.
- 3)Ensure that wiring is correct before test in order to avoid light and power supply damage;